



100%
Made in Italy



Armadi e Tavoli Refrigerati
Refrigerated Cabinets and Work tables
Armoires et Tables Refrigerées

**Gold
Line**



***Your guide to innovative
professional refrigeration***

Gold

Sp. 60 mm su tutta
la scocca



60 mm of thick. Body
Epaisseur 60mm

Esterno in acciaio AISI 304



Exterior in S/S AISI 304
Extérieur en acier inox AISI 304

Luce interna



Internal light
Lumière intérieure

Cremaiere amovibili
senza l'uso di utensili



Removable racks
tools-free
Crémaillères amovibles
sans outils

Guarnizioni removibili
per una facile pulizia



Guarnizioni removibili
per una facile pulizia

Design e tecnologia avanzata
sono le qualità salienti della
nuova linea di armadi e tavoli
refrigerati di Desmon.

Quando le esperienze, gli uomini e le idee di
un'organizzazione muovono verso obiettivi
comuni, sono possibili traguardi importanti...
DESMON, forte della pluriennale esperienza
nel segmento della refrigerazione
professionale, esprime nella nuova gamma
dei prodotti la propria filosofia realizzativa.

H.A.C.C.P.
as
standard

- Economia di gestione
- Rispetto per l'ambiente
- Funzionalità
- Design



When the experiences, the men and the ideas
of an organization move toward common
objectives, important targets are achievable.
Desmon, with its huge experience in the
segment of the professional refrigeration,
expresses its own philosophy in the big range
of the manufactured products:

- Economy of management
- Respect of the environment
- Functionality and design

Design and advanced technology
are the main quality of the new Desmon
range of cabinets and counters

La conception et la technologie avancée
sont les principales qualités de la nouvelle
gamme d'Armoires et de Tables réfrigérées
Desmon





Cruscotto incernierato per consentire facile accesso alle parti elettriche ed all'unità motocondensante.
Hinged control panel which allows easy access to the electrical parts and the motor-condenser unit

Frontal abattant

Unità refrigerante a monoblocco



Compact refrigeration system
Unité réfrigérante compacte

Fondo unico stampato con angoli arrotondati



Rounded corner int, bottom stamped in one solution

Angles arrondis à l'intérieur
Cuve emboutie.

Capacité
600/700/1200/1400/2100 L
Version TN/BT, Combinées,
Passant, poisson et pâtisserie .
Contrôle électronique
Evaporation automatique des
eaux de condensation,
3 grilles par porte GN 2/1.
Porte réversible avec fermeture
automatique.
Eclairage intérieur à l'ouverture
des portes
Fermeture à clé
Joint de porte à pression
interchangeable.
Angles arrondis à l'intérieur
Cuve emboutie.
Pieds inox réglables.

Capacità
600/700/1200/1400/2100 L litri
Versioni TN/BT, passanti, per
pesce, pasticceria
e combinati da 2-3 e 4 temp.
Controllo elettronico
Evaporazione automatica acqua
di condensa
3 griglie per porta in dotazione
Porte reversibili autochiudenti
Luce interna
Serratura con chiave
Guarnizioni removibili
Interno con angoli arrotondati e
fondo stampato
Piedini regolabili in acciaio inox

Capaci
600/700/1200/1400/2100 L lt
Versions: chillers, freezers, fish,
pastry,
dual from 2 to 4 temperatures
and Pass-through.
Electronic control
Automatic evaporation of
condensing water
3 shelves for each door
Reversible and self-closing doors
Internal light
key lock
Removable gaskets
Internal rounded corners and
stamped bottom
Adjustable s/s feet

**H.A.C.C.P.
di
serie**

Disponibile con vano abbattitore
Blast freezer section available



Struttura monoblocco
satinata esternamente
Scotch-Brite
Single unit foamed
external Scotch-Brite
satin finish
Structure monobloc
satinée extérieurement
Scotch-Brite

Gold

Sp. 60 mm su tutta
la scocca



60 mm of thick. Body
Epaisseur 60mm

Unità refrigerante estraibile
per un facile accesso in caso
di manutenzione



Slide out refrigeration
system for service access

Versioni TN/BT, Passanti e
Combinati
Controllo elettronico
Evaporazione automatica
acqua di condensa
1 griglia per porta in
dotazione
Porte autochiudenti
Serratura con chiave a
richiesta
Guarnizioni removibili
Interno con angoli arrotondati
e fondo stampato
Piedini in acciaio inox
regolabili in altezza
Unità condensante estraibile
su guide

H.A.C.C.P.
as
standard

Tavoli refrigerati (GN 1/1) da 1 a 5 porte,
cassetti da 1/2, 1/3 e 2/3, cassetto
neutro o refrigerato su vano motore.

Refrigerated work tables
(GN 1/1) from 1 to 5 doors,
drawers of 1/2, 1/3 e 2/3,
neutral or refrigerated drawer
above compressing unit.



Version Available:
Chiller, freezer, Double temp.
and Pass-trough
Electronic control
Automatic evaporation of
condensing water
1 shelf each door
Self closing doors
Key lock available
Removable gaskets
Internal rounded corners with
stamped bottom
Adjustable s/s feet
Removable condensing unit

Piano con alzatina



Splashback
Dosseret arrière

Disponibile dans
différentes versions:
Positives, négatives,
Combinées et 2 Temp..
Contrôle électronique
Evaporation automatique
des eaux de condensation.
1 grill par portillon.
Eclairage intérieur à
l'ouverture des portes
Fermeture à clé sur
demande
Joint de porte à pression
interchangeable.
Angles arrondis à l'intérieur
Cuve emboutie.
Pieds inox réglables.



Tables réfrigérées de 1 à 4 portes (GN 1/1 - Euronorm)
Tiroirs de 1/2, 1/3 et 2/3



Tavoli da lavoro con unità refrigeranti remote

**H.A.C.C.P.
di
serie**



Work table depth, 70 cm
1 plastic coated shelf on each door 530x325 mm
Predisposition for remote compressor with thermostatic valve
Electronic control
Ventilated
Automatic defrost
External/Internal in S/S AISI 304
1 plastic coated shelf per each door dim. 530x325 mm
Polyurethane insulation CFC free 60 mm. of thickness
Adjustable feet in S/S
Ambient temperature + 43° C
Gas: R404a
For TGM2R e TGB2R:
2 doors
For TGM3R e TGB3R:
3 doors
For TGM4R e TGB4R:
4 doors

Tavolo refrigerato profondità 70cm
Nr. 1 griglia plastificata per vano dim. 530x325 mm
Predisposizione per gruppo remoto con valvola termostatica
Controllo elettronico
Ventilato
Sbrinamento automatico
Interno / esterno acciaio inox AISI 304
Isolamento senza CFC sp.60mm
Piedini regolabili Inox
Temperatura Ambiente fino a + 43°C
Gas : R404a
Per TGM2R e TGB2R:
2 sportelli
Per TGM3R e TGB3R:
3 sportelli
Per TGM4R e TGB4R:
4 sportelli



Remote unit work table

Table profondeur 70cm
Préparée pour moteur a distance avec soupape thermostatique
Contrôle électronique
Ventilé
Cycle de degivrage automatique
Révêtement exteireur/intérieur en acier inoxydable AISI 304
N. 1 grille dim. 530x325 mm dans chaque cuve
Isolament sans CFC de 60 mm
Pieds réglables en inox
Température ambiante + 43 ° C
Gas : R404a
Pour TGM2R - TGB2R
2 portillons
Pour TGM3R - TGB3R
3 portillons
Pour TGM4R - TGB4R
4 portillons



Gold

**Tables de travail
avec unité
réfrigérante a
distance**

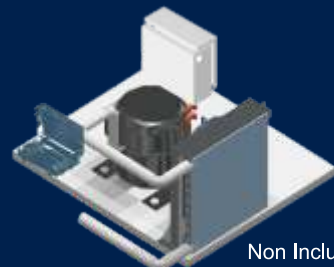

Non Inclusa
Not included
Option

Rapida rimozione del cassetto per una facile pulizia



Quick and simple drawer removal for easy cleaning

Cremagliere amovibili senza l'uso di utensili



Removable racks tools-free
Crémaillères amovibles sans outils



SERIES "GM" 700LT

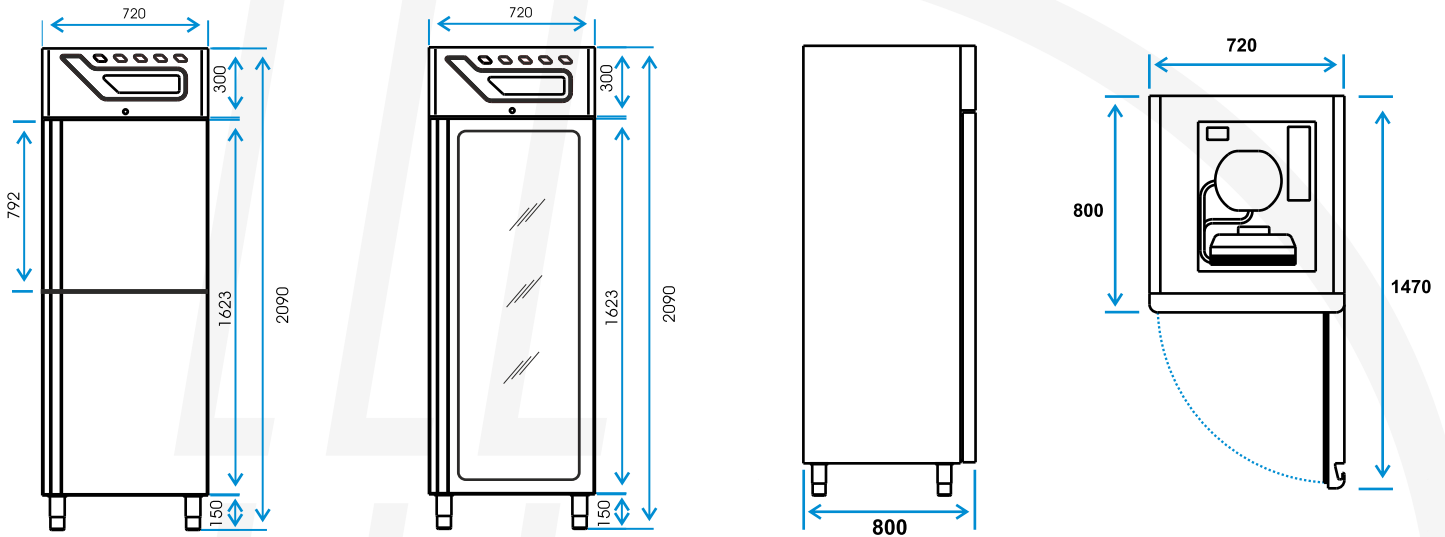

SERIES "TGM"

TGM100 - TGM2 - TGM3 - TGM4

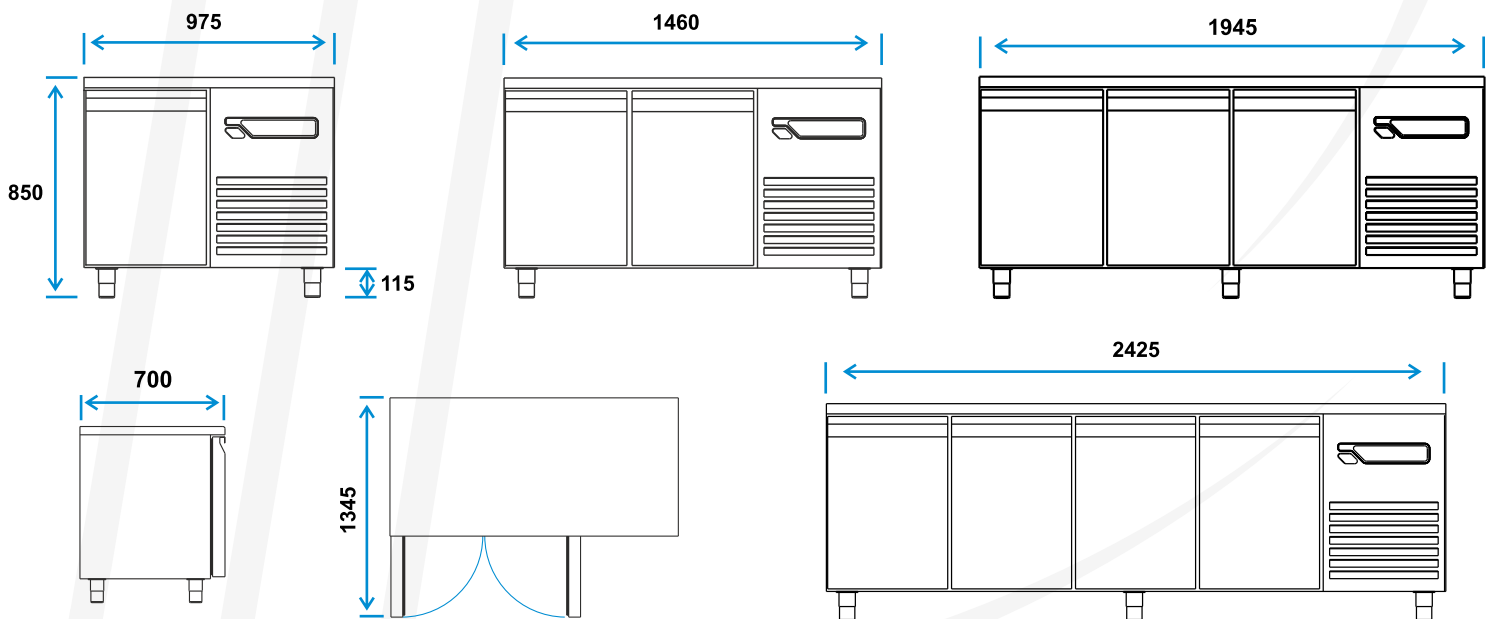

SERIES "GM" 1400LT

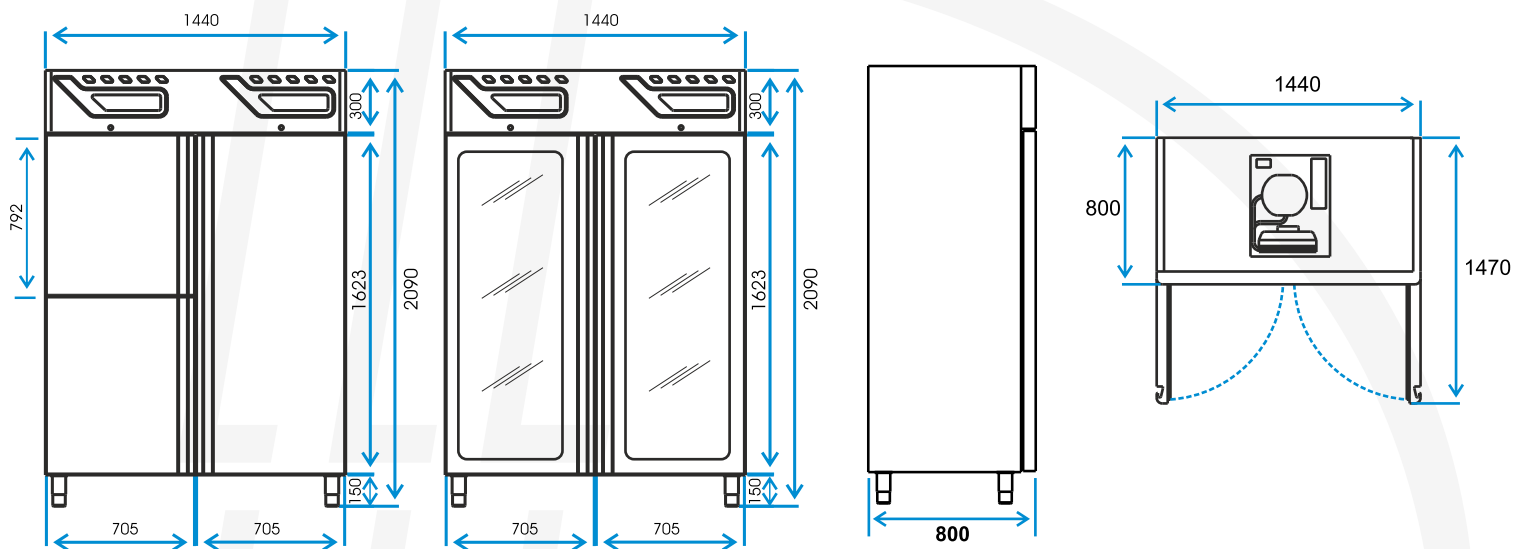

SERIES "TGM R"

TGM2R - TGM3R - TGM4R

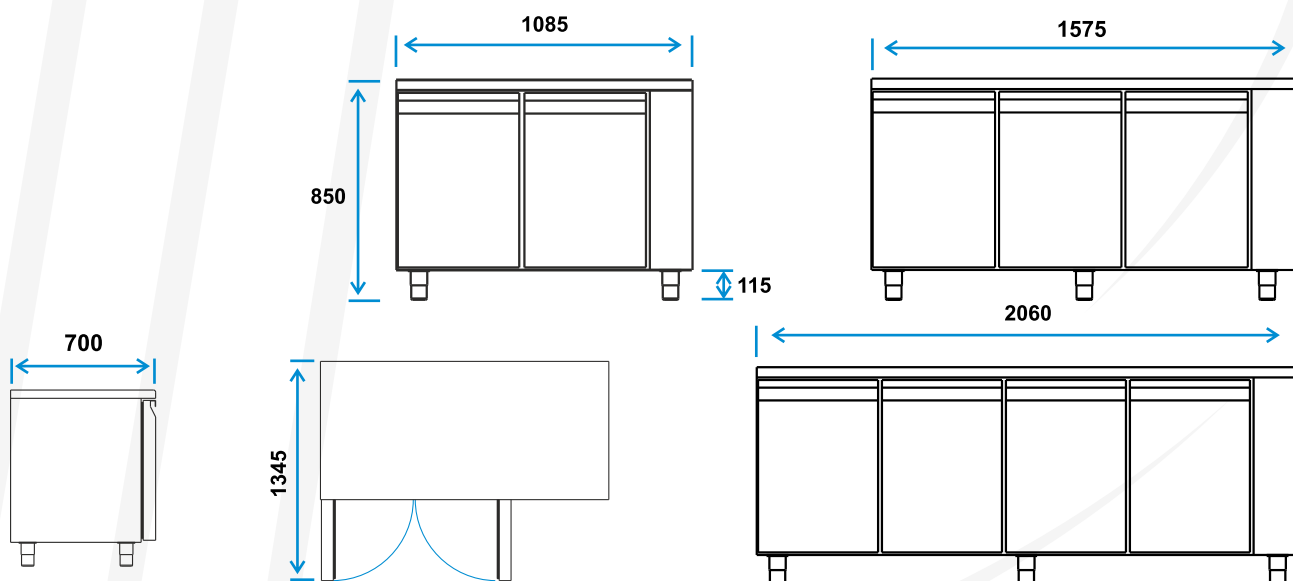



UNITED COLORS OF DESMON



100% Made in Italy



MANUFACTURING PLANTS:

DESMON S.p.A.

Head Office:

Zona Ind. F3 Sup.

83051 Nusco (AV)

ITALIA

Tel.: +39 0827 607318

Fax: +39 0827 607009

E-mail: info@desmon.it

www.desmon.it

